

In Process Sketch / Szkic Operacyjny

KONTROLA WYMIAROWA

Group: CHASSIS Plant: PRASZKA

Op.-Description: Op.-Opis:

Release-No.: see cover page
Zwolnienie Nr.: patrz str. glowna

Part-Name: WALEK
Nazwa detalu:

Do not scale / Rys. nie w skali!

<input type="checkbox"/>	Prototype	<input type="checkbox"/>	Control Item	<input type="checkbox"/>	Yes	<input checked="" type="checkbox"/>	No
<input checked="" type="checkbox"/>	Pre-Launch Production	<input type="checkbox"/>	Tok	<input type="checkbox"/>	No	<input checked="" type="checkbox"/>	Part-Name: Nr detalu:

E0007430.A

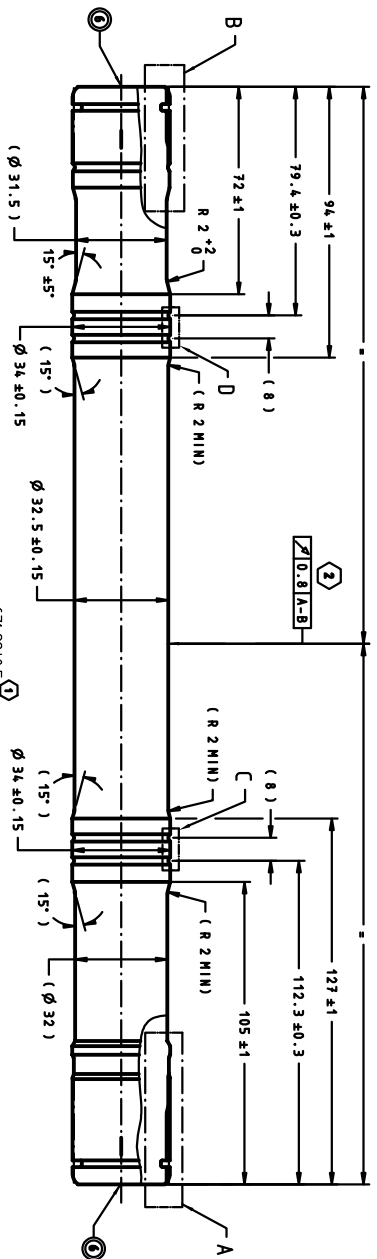

POTENTIAL SIGNIFICANT CHARACTERISTICS	
1	14h.5
2	0.81A-B
3	2.3h.1
4	2.3h.1
5	HEAT TREATMENT

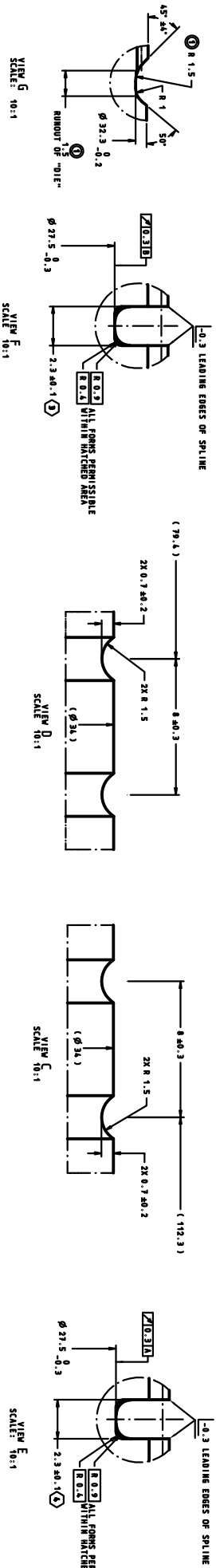
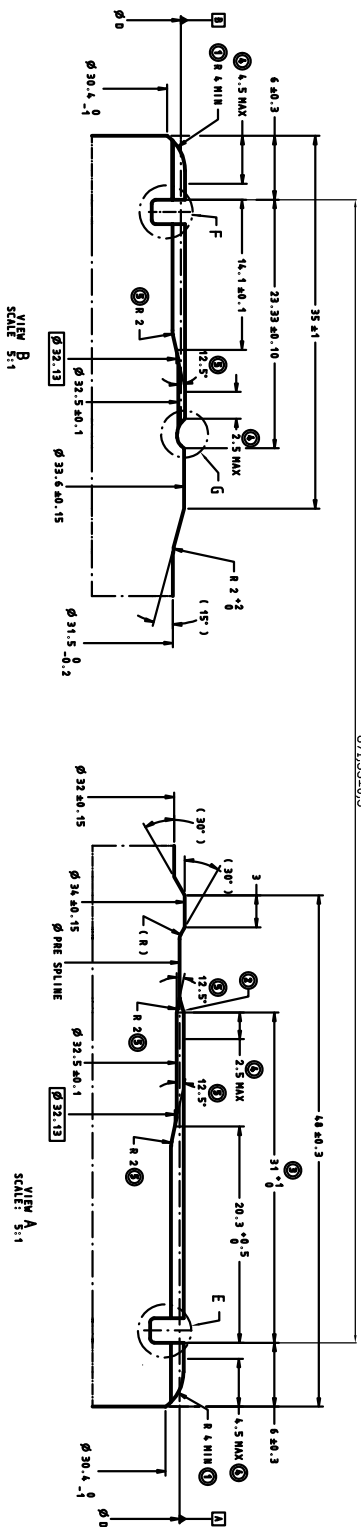

VIEW G SCALE: 10:1

VIEW E SCALE: 10:1

VIEW D SCALE: 10:1

VIEW C SCALE: 10:1

VIEW F SCALE: 10:1

Mash. Type:	
Typ Maszynowy:	
BT:	Op.No.:
Nr Tabl:	Op.Nr.:
Proc.Engr.Group:	Date: 10.09.2024
Zespoł Inz.:	Sht.:
Inz. Procesu:	SKic:
	1 of 1

Group:
Dywizjo:

CHASSIS

Plant:
Zaklad:

PRASZKA

Op.-Description:
Op.-Opis:

In Process Sketch / Szkic Operacyjny

KONTROLA WYMIAROWA

Release-No.: see cover page
Zwolnienie Nr.: patrz str. glowna

Part-Name: WALEK
Nazwa detalu:

Do not scale / Rys. nie w skali

<input type="checkbox"/>	Prototype	<input type="checkbox"/>	Control	<input type="checkbox"/>	Yes	<input type="checkbox"/>	No	Part-No.:
<input type="checkbox"/>	Pre-Launch	<input type="checkbox"/>	Item	<input type="checkbox"/>	Tak	<input checked="" type="checkbox"/>	Nie	Nr detalu:
<input checked="" type="checkbox"/>	Production							

E0007432.A

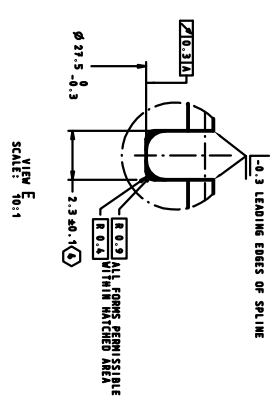
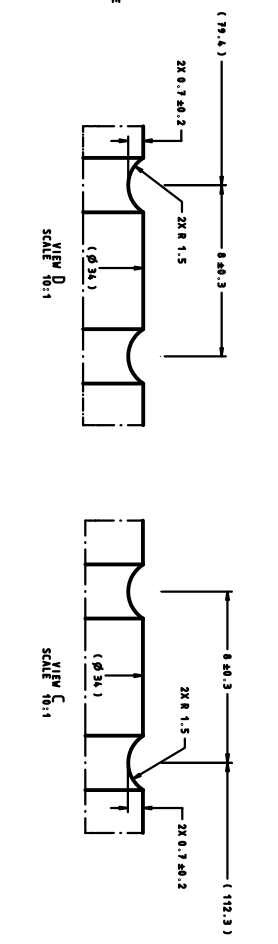
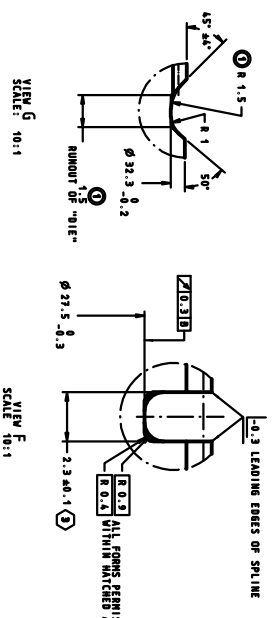
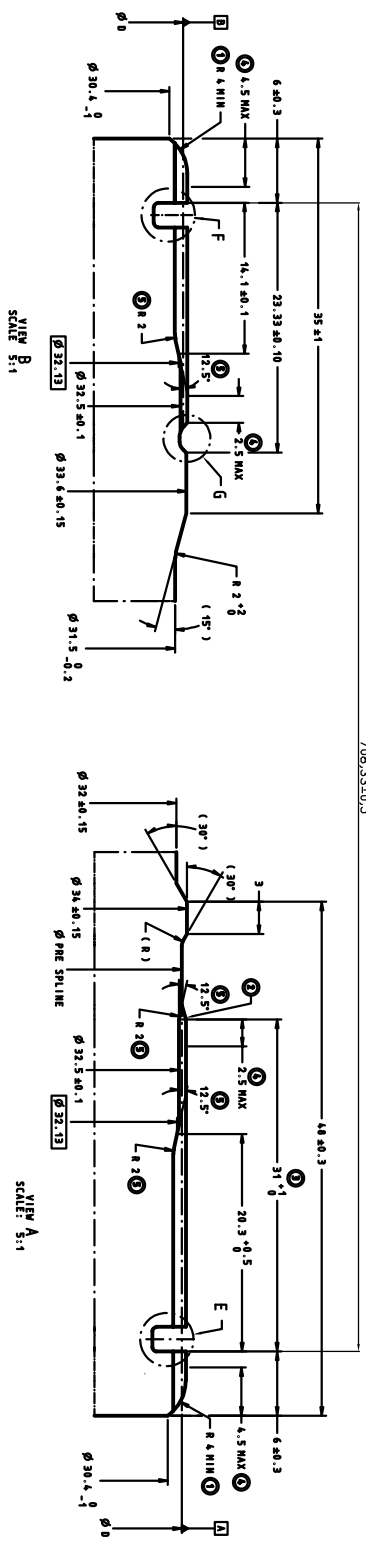
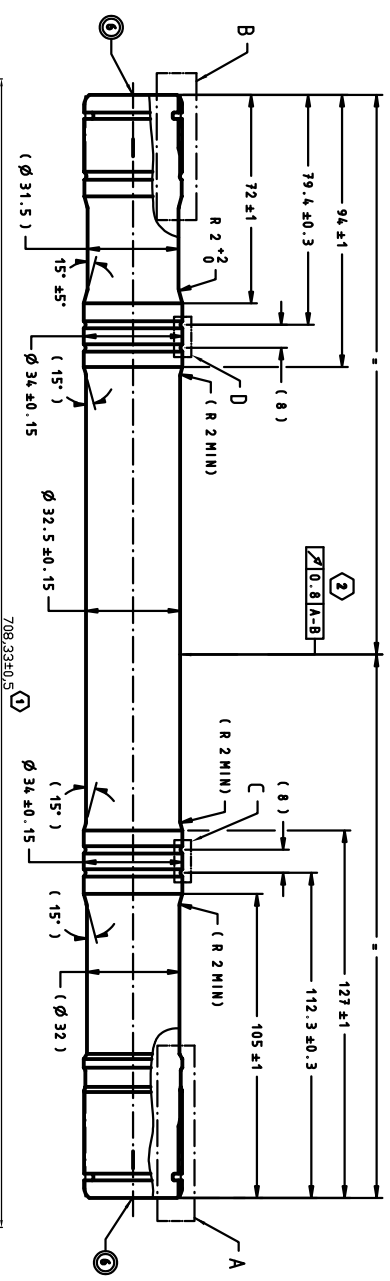

Mash. Type:	
Typ Maszynny:	
BT:	Op.No.:
Nr. Tabl.:	Op.Nr.:
Proc.Engr.Group:	Date: 10.09.2024
Zespól Inz.:	Sht.: 1 of 1
Proc.Engr.:	Szkic: 1 of 1
Inz. Procesu:	

Group: CHASSIS Plant: In Process Sketch / Szkic Operacyjny Op.-Description: KONTROLA WYMIAROWA
 Dywizja: patrz str. glowna WALEK Zaklad: PRASZKA Op.-Opis: 1 of 1

Release-No.: see cover page Part-Name: WALEK Do not scale / Rys. nie w skali
 Zwolnienie Nr.: patrz str. glowna Nazwa detalu: Part-No.: E0002675.A

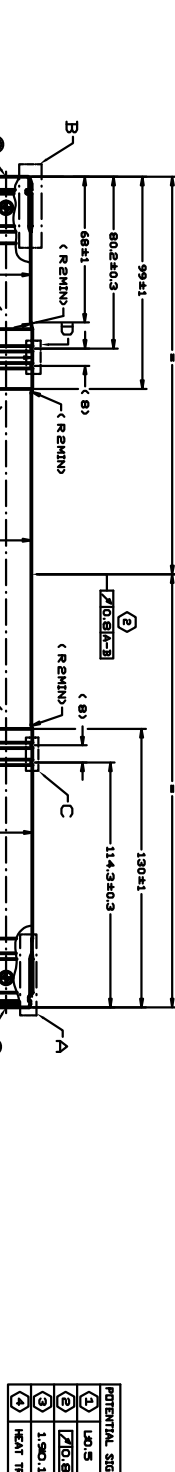

POTENTIAL SIGNIFICANT CHARACTERISTICS
(1) 130.5
(2) 70.8/A-3
(3) 1.90.1
HEAT TREATMENT

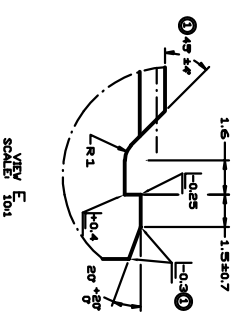
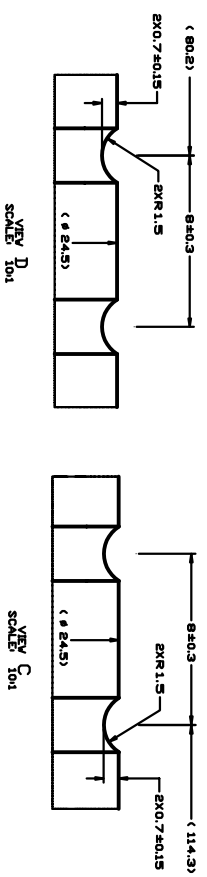
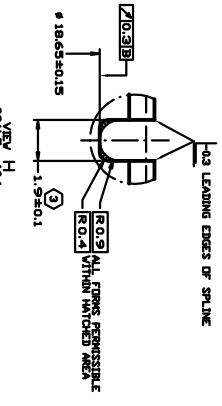
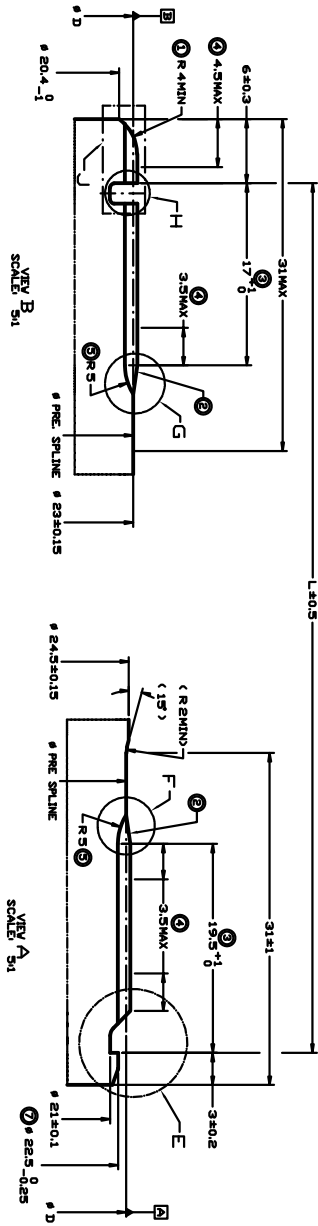

Mash. Type: Typ Maszynowy:		Op.No.:
BT:		Op.Nr.:
Nr Tabl:		Date:
Proc.Engr.Group:		Sht.:
Zespół Inz.:		SZKIC:
Proc.Engr. Inz. Processu:		1 of 1

Date: 10.09.2024

Group:
Dywizja:

CHASSIS

Plant:
Zakład:

In Process Sketch / Szkic Operacyjny
PRASZKA

Op.-Description:
Op.-Opis:

KONTROLA WYMIAROWA

Release-No.: see cover page
Zwolnienie Nr.: patrz str. główna

Part-Name: WALEK
Nazwa detalu:

Do not scale / Rys. nie w skali

Prototype
 Pre-Launch
Production Item

Control
 Yes
 No

Part-No.:
Nr detalu:

E0005103.A

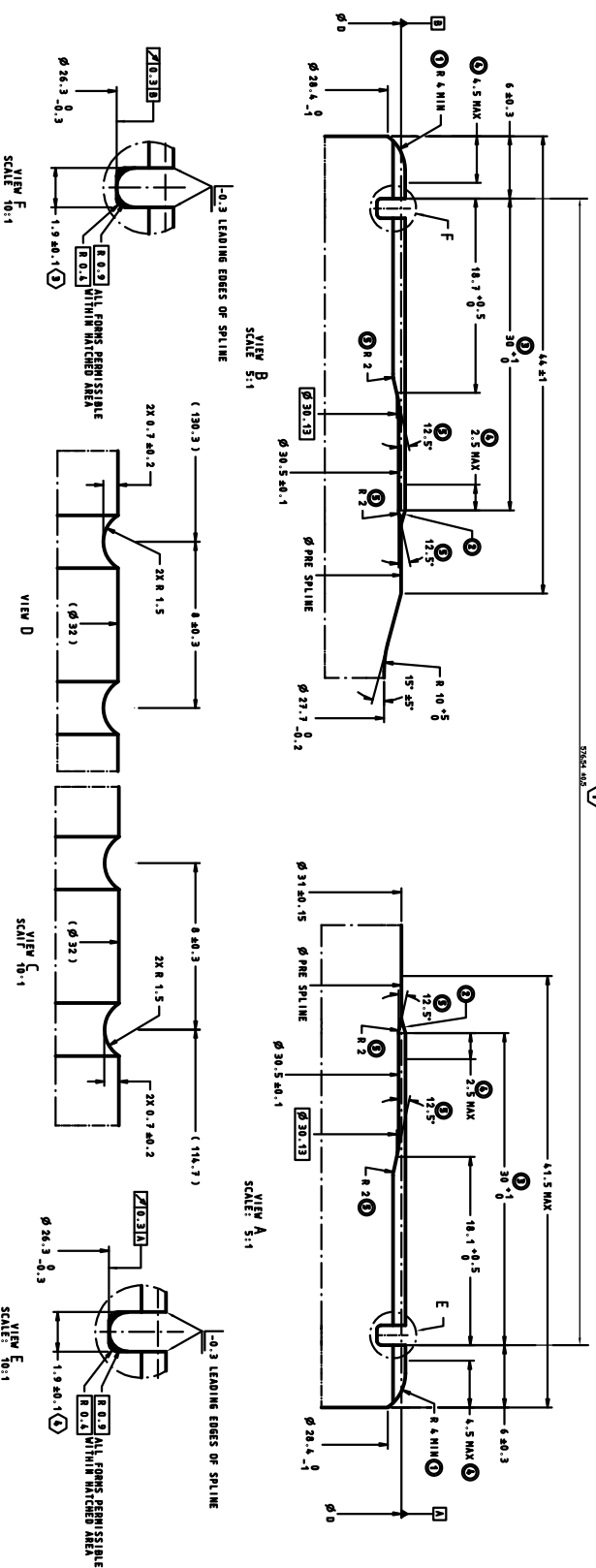
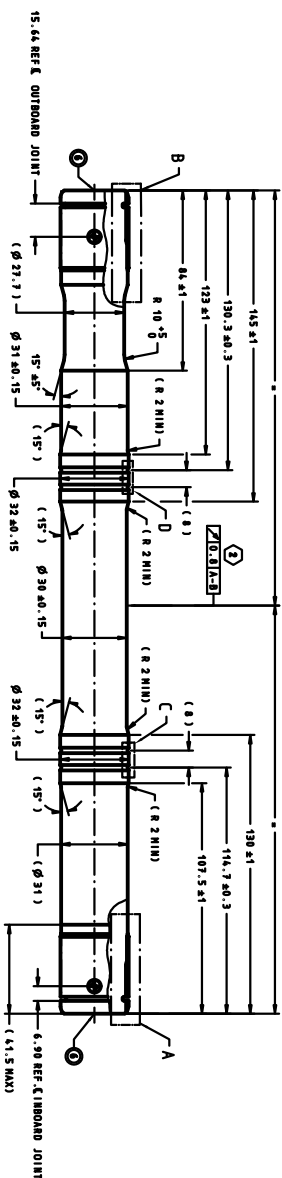

Group: CHASSIS
 Plant: PRASZKA
 Dywizja: Zakład

In Process Sketch / Szkic Operacyjny

KONTROLA WYMIAROWA

Release-No.: see cover page
 Zvolnienie Nr.: patrz str. glowna

Part-Name: WALEK
 Nazwa detalu:

Do not scale / Rys. nie w skali!

Prototype
 Pre-Launch
 Production
 Control Yes No
 Tak Nie

Op-Description: Op.-Opis:
 Part-No.: E0005104.A
 Nr detalu:

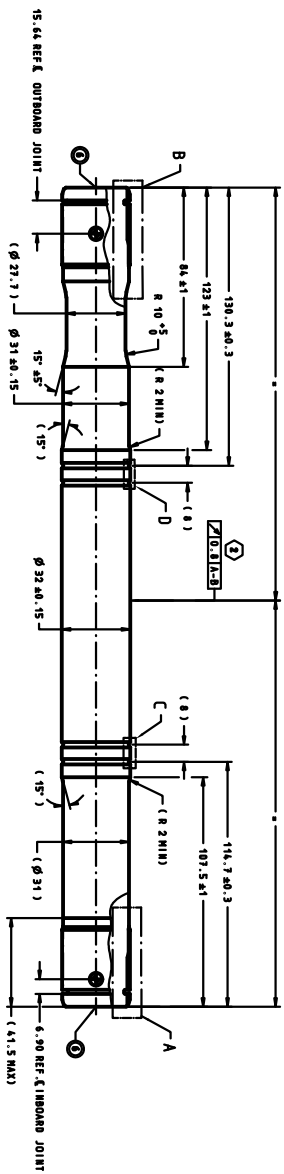

POTENTIAL SIGNIFICANT CHARACTERISTICS	
1	LD.5
2	[D.31C-B]
3	1.500.1
4	1.500.1
5	HEAT TREATMENT

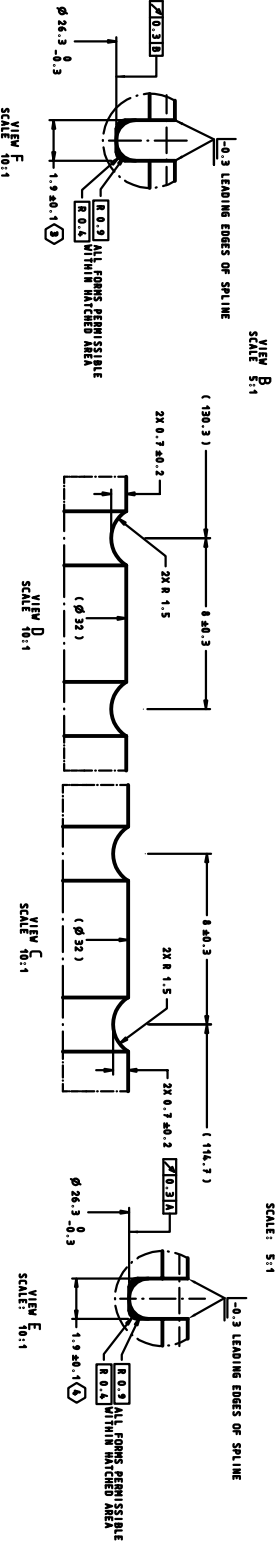
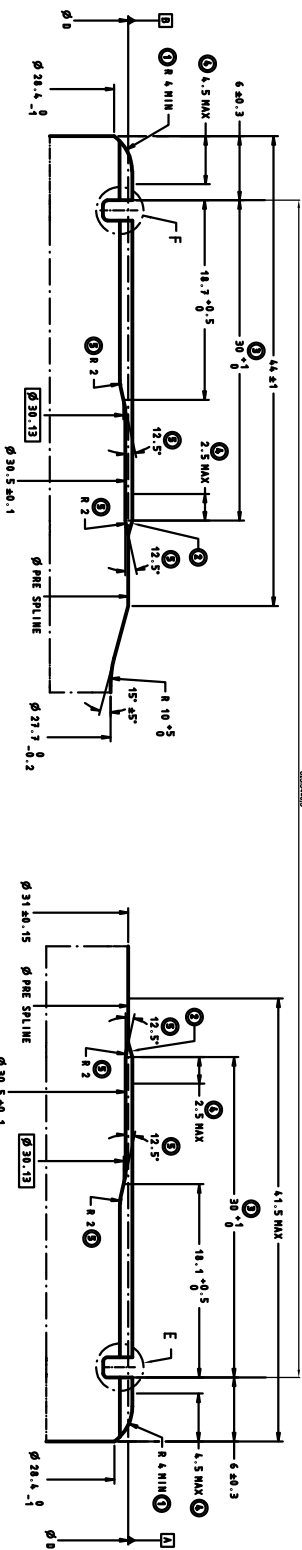

Mash. Type:	Op.No.:
Typ Maszyny:	Op.Nr.:
Bf.:	Date: 10.09.2024
Nr. Tabl.:	Szt.: 1 of 1
Proc.Engr.Group:	Szkic: 1 z 1
Zespół Inz.:	
Proc.Engr.:	
Inz. Proceusu:	

Group: CHASSIS
Dywizja:

Plant: PRASZKA
Zakład:

Op.-Description:
Op.-Opis:

KONTROLA WYMIAROWA

Release-No.: see cover page
Zwolnienie Nr.: patrz str. glowna

Part-Name: WALEK
Nazwa detalu:

Do not scale / Rys. nie w skali!

Prototype
 Pre-Launch
 Production
 Control Item
 Yes
 No
 Tak
 Nie

Part-No.:
Nr detalu:

E0005105.A

In Process Sketch / Szkic Operacyjny

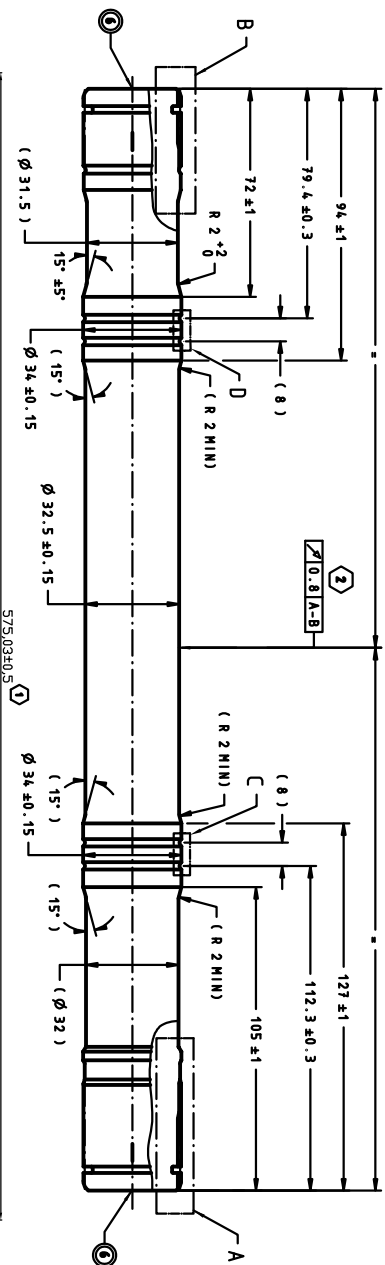

POTENTIAL SIGNIFICANT CHARACTERISTICS	
1	LEN. 5
2	√0.8 A-B
3	2.300.1
4	2.200.1
5	HEAT TREATMENT

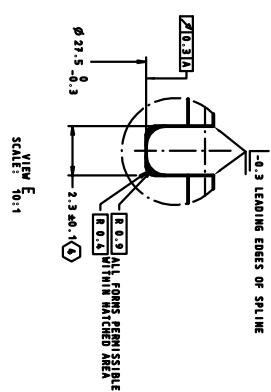
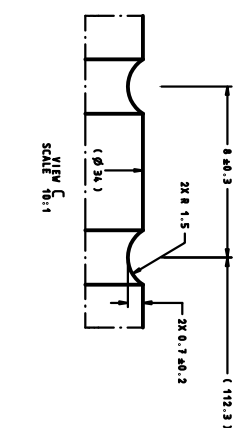
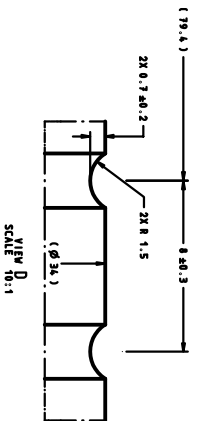
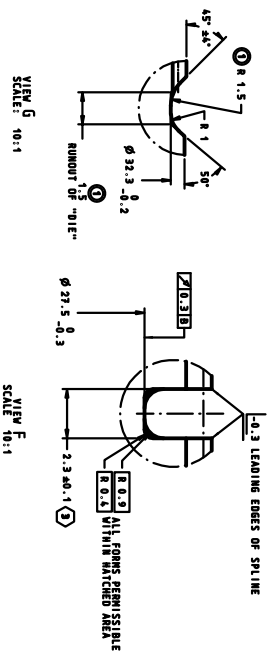
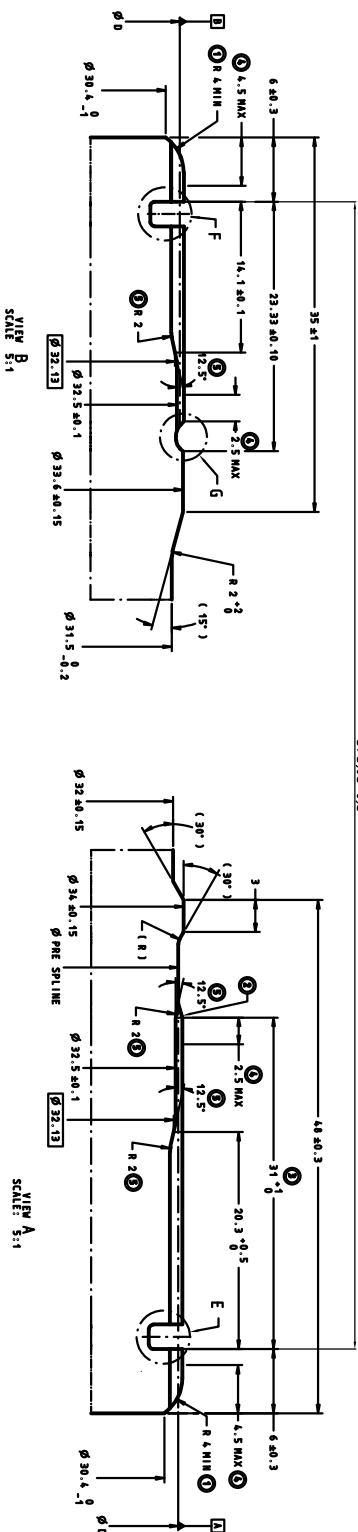

Mash. Type: _____
Typ Maszyny: _____
BT: _____
Nr. Tabli: _____
Op.No.: _____
Proc. Engr. Group: _____
Zespol. Inz: _____
Proc. Engr.: _____
Inz. Procesu: _____
Date: 10.09.2024
Sht.: 1 of 1
Szkic: 1 z 1

Group: CHASSIS
Dywizja:

Plant: PRASZKA
Zakład:

In Process Sketch / Szkic Operacyjny

Op.-Description: Op.-Opis:

KONTROLA WYMIAROWA

Release-No.: see cover page
Zwolnienie Nr.: patrz str. glowna

Part-Name: WALEK
Nazwa detalu:

Do not scale / Rys. nie w skali!

Prototype
 Pre-Launch
 Production

Control Item Yes No
Tak Nie

Part-No.:
Nr detalu:

E0005106.A

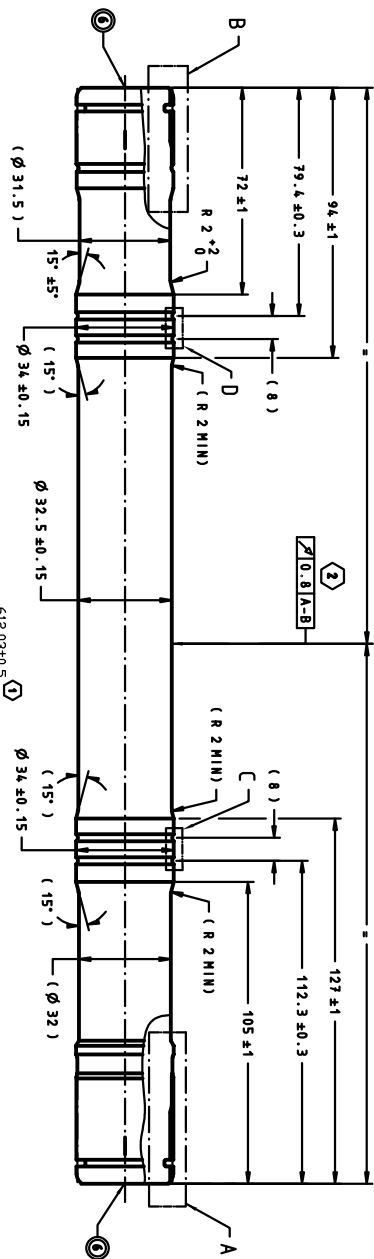

POTENTIAL SIGNIFICANT CHARACTERISTICS	
1	1.40.5
2	2/0.81A-B
3	2.30.1
4	2.30.1
5	HEAT TREATMENT

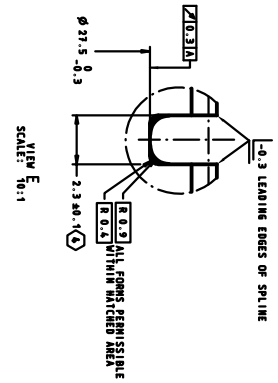
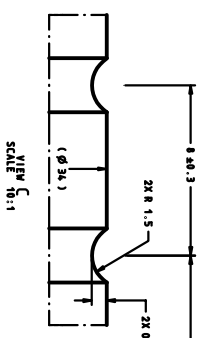
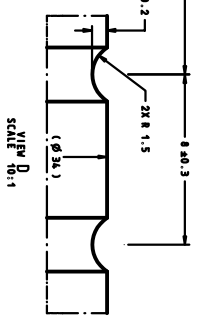
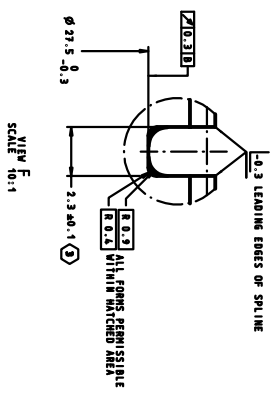
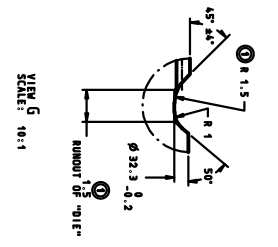
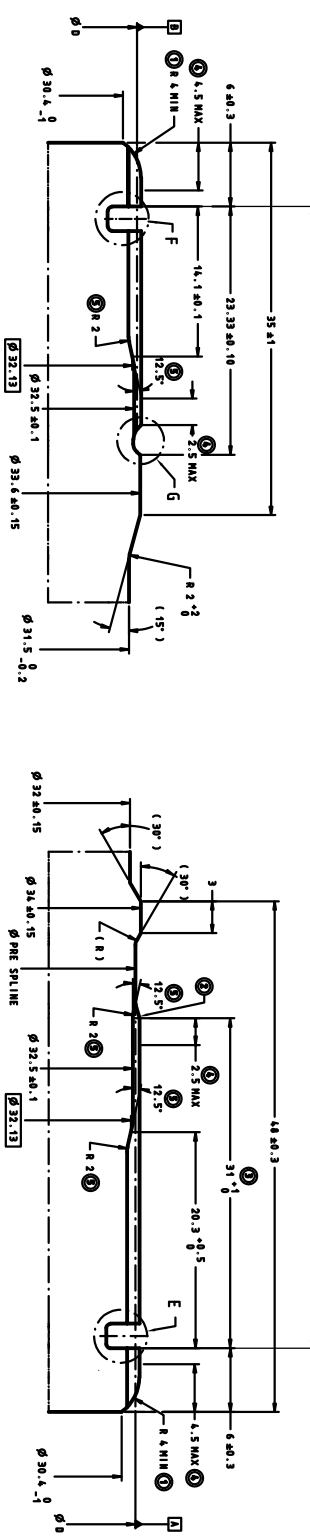

Mash. Type: Typ Maszynowy	Op. No.:
BT:	Op. Nr.:
Nr. Tabli:	Date: 10.09.2024
Proc.Engr. Group: Zespół Inż.:	Sht.:
Proc.Engr. Inz. Procesu:	Sht. of 1
	Szkiec: 1 z 1

In Process Sketch / Szkic Operacyjny

KONTROLA WYMIAROWA

Group: CHASSIS
Dywizja:

Plant: PRASZKA
Zaklad:

Op.-Description: _____
Op.-Opis: _____

Release-No.: see cover page
Zwolnienie Nr.: patrz str. glowna

Part-Name: **WALEK**
Nazwa detalu:

Prototype
 Pre-Launch
 Production

Control Item Yes No
Tak Nie

Part-No.: _____
Nr detalu:

E0007355.A

Do not scale / Rys. nie w skali

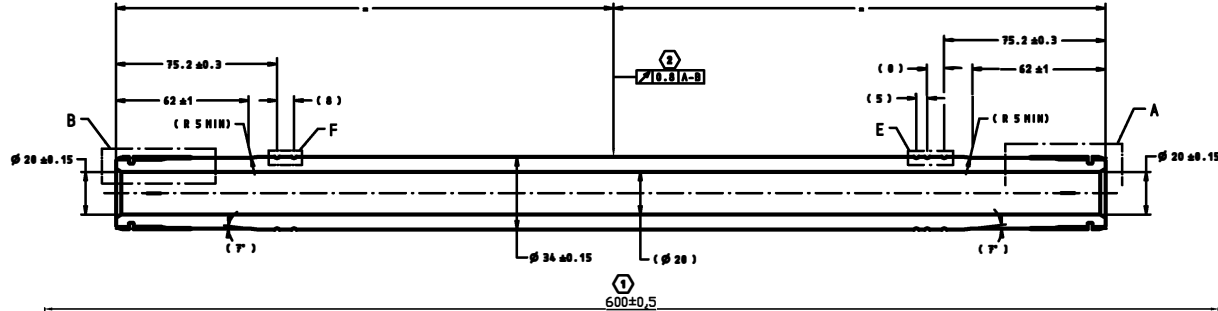

POTENTIAL SIGNIFICANT CHARACTERISTICS	
(1)	L60.5
(2)	2/0.3(A-B)
(3)	2.360 ± 0.1
(4)	2.360 ± 0.1
(5)	HEAT TREATMENT

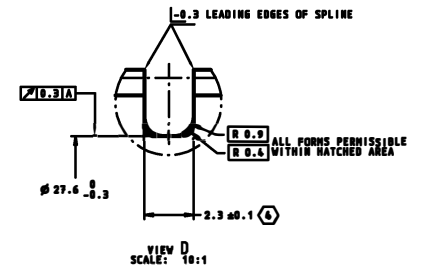
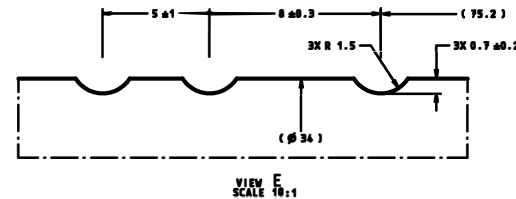
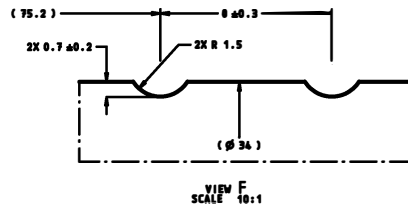
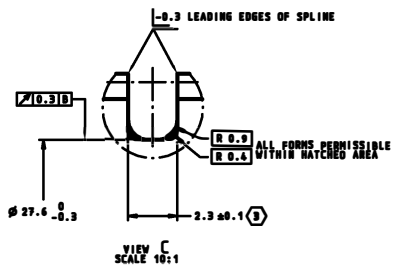
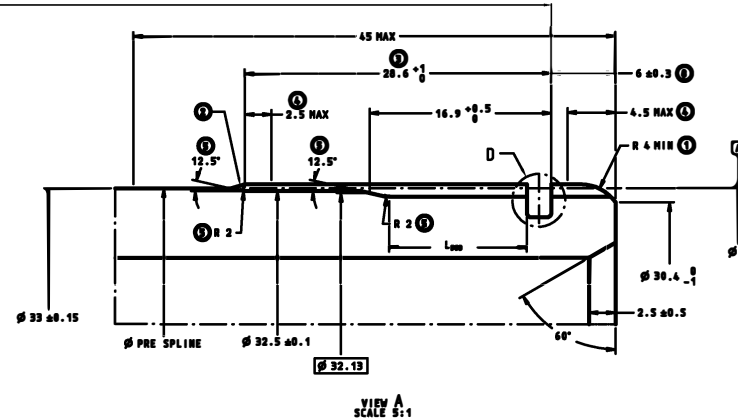
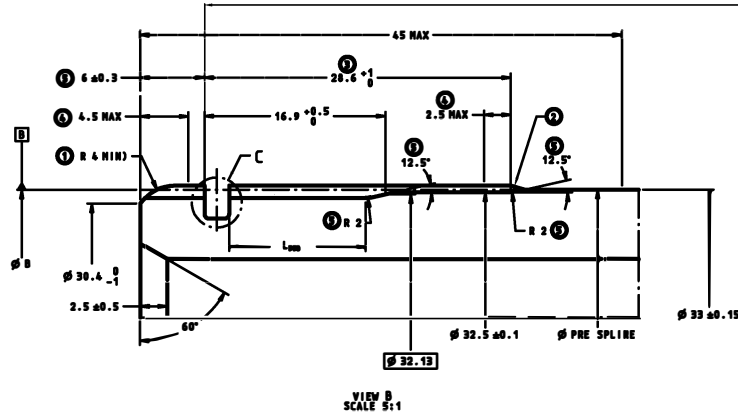

Mash. Type:
Typ Maszyny:

BT:
Nr Tabl:

Proc.Engr.Group:
Zespol Inz:

Proc.Engr. :
Inz. Procesu:

Op.No.:
Op.Nr :

Date: 10.09.2024

Sht.: 1 of 1
Szkic: z 1